

Mobile Generator – MMG235 Specifications

ENGINE

- John Deere® PE6068HF485 - turbocharged, diesel engine
 - Prime - 286 hp @ 1800 rpm
 - Standby - 315 hp @ 1800 rpm
 - 6 cylinder
 - 6.8 L displacement
 - Tier III approved
- Steel, single wall fuel tank
 - 342 gal. capacity
 - 313 usable gallons
 - 21 hr. run time – full load
 - Fuel tank built into skid of generator set
- Fuel consumption at prime:
 - 100% - 15.2 gph (57.5 Lph)
 - 75% - 11.4 gph (43.2 Lph)
 - 50% - 7.6 gph (28.8 Lph)
- Cooling system capable of operating at 120°F ambient
- Low coolant shutdown
- Radiator and oil drains plumbed to exterior
- Rubber vibration dampers isolate engine/generator from frame
- Disposable air filter - paper element
- Air filter restriction indicator mounted on control panel
- 60 Hz engine/generator
- Electronic isochronous governing

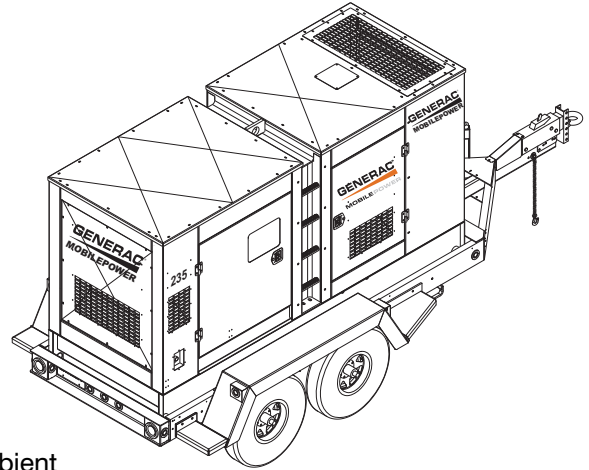

GENERATOR

- Marathon Electric®
 - Brushless
 - 4 pole
 - Class H insulation
- Voltage regulation +/- 1% with Marathon SE350 Voltage Regulator

SYSTEM OUTPUT

- Link / Reconnect Board:
 - Three phase – 120 / 208V Low Wye
 - Three phase – 277 / 480V High Wye
- 204 kW / 255 kVA – standby, three phase
- 186 kW / 233 kVA – prime, three phase

SYSTEM CONTROLS

- Microprocessor-based controller
 - Backlit, 128x64 pixel resolution display
 - -40°F to 185°F operating temperature range
 - Thermostatically controlled LCD heater

- Six LED indicators w/ lamp test
 - ◆ Alarm / Fault (Red)
 - ◆ Ready / Manual (Red)
 - ◆ Running (Green)
 - ◆ Warning (Yellow)
 - ◆ Ready / Auto (Green)
 - ◆ Supplying Load (Green)
- Push buttons for easy operation
 - Manual or Auto Start
 - Engine Start or Stop
 - Alarm Cancel & Fault Reset
 - Scrolling Arrows for Diagnostic Information
 - ◆ System kW output display
 - ◆ Line output & frequency display
 - ◆ Engine diagnostic display
 - Oil pressure
 - Engine temperature
 - Fuel level
 - Battery
 - ◆ System hours
 - Running hours
 - kW hours
 - Time to service
 - Alarm list – warnings / shutdowns are date & time stamped
 - ◆ Fuel level: warning – 15%; shutdown – 5%
 - ◆ Overspeed protection: shutdown – 115%
 - ◆ Oil pressure: warning – 25 psi; shutdown – 20 psi
 - ◆ Coolant temperature: warning – 220°F; shutdown – 230°F
 - ◆ Battery voltage: over – 15VDC; under – 11VDC
 - ◆ Generator over voltage: warning – 110%; shutdown – 111%
 - ◆ Generator under voltage: warning – 87%; shutdown – 86%
 - ◆ Generator over frequency: warning – 105%; shutdown – 110%
 - ◆ Generator under frequency: warning – 95%; shutdown – 90%
 - ◆ Over current shutdown

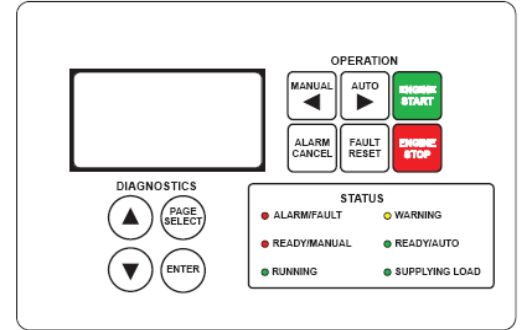

ELECTRICAL CONTROLS

- Remote start / stop contacts located next to lug box
- Lockable control box door with diagnostics window
- Lockable lug box with safety switch
 - Trips main breaker when lug door is opened
 - Disables voltage regulator
- Cable entry guides to the lug box
 - Restricts access of foreign objects
- Output ground connection lug inside lug box
- 800A main breaker with shunt trip
- Convenience receptacles with individual breakers (restricted use in high wye mode)
 - (2) 120V 20 Amp GFCI duplex outlets (Nema 5-20R type)
 - (3) 125 / 250V 50 Amp, 3 pole, 4 wire twistlock (Non-Nema 6369)
- Panel mounted rheostat for voltage adjustment - +/- 10%
- 1000 CCA wet cell battery

ENCLOSURE

- Generac Mobile Power decals
- Aluminum, sound attenuated enclosure
 - UV & fade resistant, high temperature cured, white polyester powder paint
 - Insulated and baffled
 - 68 dB(A) at 23 feet – prime power
- Fully lockable enclosure including doors and fuel fill
- Stainless steel hinges on doors
- Emergency stop switch located on outside of enclosure
- Central lifting point
- Multi-lingual operating/safety decals
- Document holder with operating manual including AC/DC wiring diagrams

TRAILER

- DOT approved tail, side, brake, and directional lights
 - Recessed rear lights
- Transportation tie downs
- Safety chains with spring loaded safety hooks
- 3" lunette ring hitch
- (2) 7000 lb. axles with surge brakes
- 5000 lb. tongue jack with footplate
- ST235/80R16 tubeless tires – 10 ply

WEIGHTS & DIMENSIONS

Skid mounted

- Dry weight: 6510 lbs (2953 kg)
- Operating weight: 9100 lbs (4128 kg)
- 132 x 50 x 77 in
(3.35 x 1.27 x 1.96 m)

Trailer mounted

- Dry weight: 8450 lbs
(3833 kg)
- Operating weight: 11040
lbs (5008 kg)
- 210 x 86 x 93 in
(5.33 x 2.18 x 2.36 m)

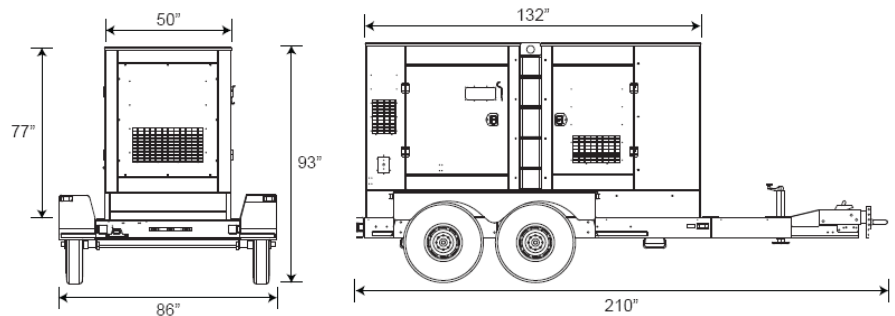

WARRANTY

- Engine and generator covered under OEM warranty – consult factory for details.

CERTIFICATIONS

- CSA certified

MMG235 Options

ENGINE OPTIONS

- ◆ In-line engine block heater (Kim Hotstart)
- ◆ Fuel transfer pump

ELECTRICAL CONTROLS OPTIONS

- ◆ Battery disconnect
- ◆ Battery charger – 2A trickle

GENERATOR OPTIONS

- ◆ PMG Generator - critical grade power quality
- ◆ Super Start Generator - motor starting applications

VOLTAGE OUTPUT OPTIONS

- ◆ 4 position phase switch
 - Single phase – 120 / 240V Zig Zag
 - Three phase – 120 / 208V Low Wye
 - Three phase – 277 / 480V High Wye
 - Three phase – 120 / 240V Delta
- ◆ Dedicated voltage configurations
- ◆ Buck Transformer kit - Provides 120V at GFCI outlets when in 277/480V
- ◆ Cam locks

SYSTEM CONTROLS OPTIONS

- ◆ Auxiliary strobe/audible indication for soft & hard alarm conditions

COOLANT OPTIONS

- ◆ 60/40 Coolant - cold weather applications

ENCLOSURE OPTIONS

- ◆ Fire extinguisher
- ◆ Interior cabinet light
- ◆ Control panel light

FUEL TANK OPTIONS

- ◆ 36 hr. single wall fuel tank
- ◆ 13 hr. double wall fuel tank
- ◆ 120% Containment

TRAILER OPTIONS

- ◆ Tandem axle trailer w/ electric brakes
- ◆ 6 pin or 7 spade electrical connectors
- ◆ Spare tire/wheel kit